



Installation Guide

J72 Parking Brake Control Kit

Application: Workhorse RV Chassis W24 & 05 P32

Model Years: 2004-2007

Part# US2078



Benefits

- Replaces the factory control module without buying a complete pump assembly.
- Prevents potential parking brake damage caused by factory control failure or wiring issues.
- Helps prevent unwanted brake lockup while driving.
- Helps prevent pump failures.
- Aids in diagnostics if issues arise with parking brake system.
- Easy installation - Plugs into factory harness.
- 3 year parts warranty



Installation Guide

J72 Parking Brake Control Kit

Application: Workhorse RV Chassis W24 & 05 P32

Model Years: 2004-2007

Part# US2078

- 1- Table of Contents
- 2- Initial Steps
- 3- Installing the UltraSave Valve
- 4- Installing the Controller
- 5- Switch & Electrical Connections
- 6- Hydraulic Connections
- 7- Review of Installation
- 8- Testing of Installation
- 9- Important Information

Tools Required

- 5/8" End Wrench
- 9/16" End Wrench
- 7/16" End Wrench
- 7/16" Socket with Ratchet
- 5/16" Socket with Drill Adaptor
- 3/4" End Wrench
- Drill Motor and 1/4" Drill Bit
- Wire Cutters (for zip ties)

This Kit Contains





Installation Guide

J72 Parking Brake Control Kit



Application: Workhorse RV Chassis W24 & 05 P32

Model Years: 2004-2007

Part# US2078

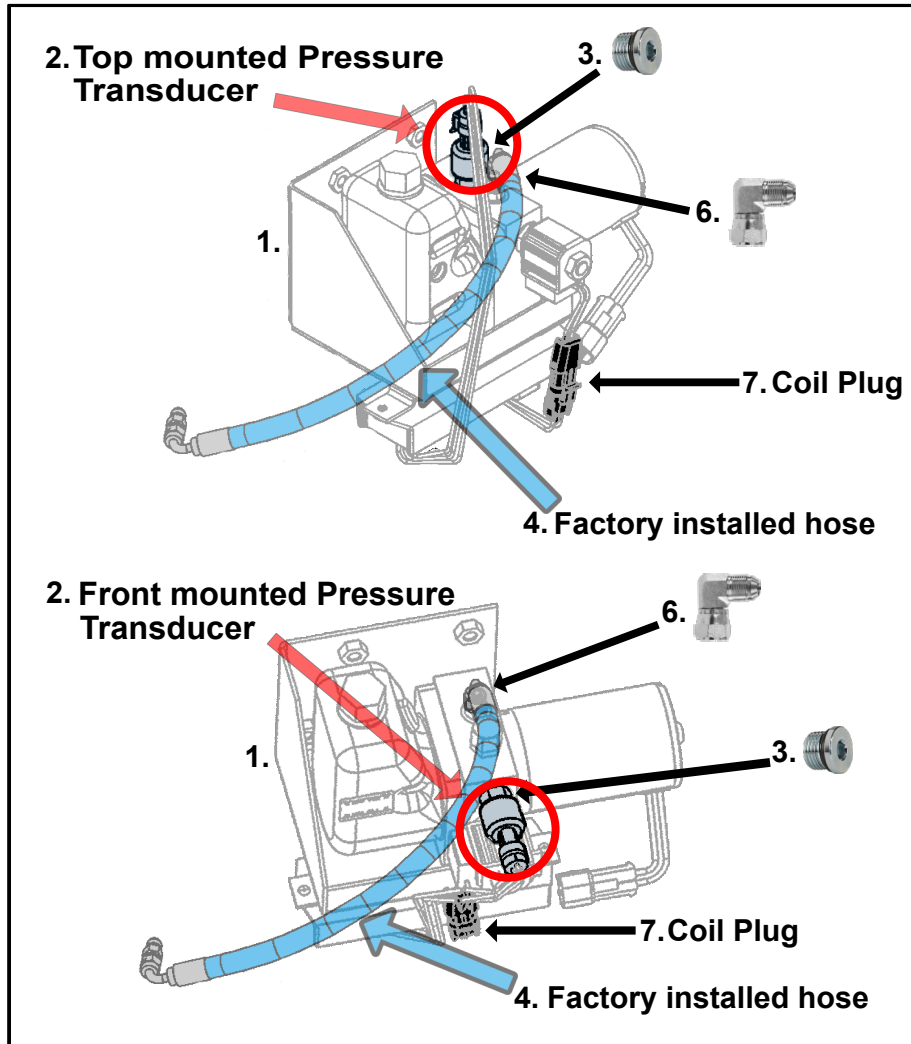
Factory Pumps



1. Locate the parking brake pump under the hood on the driver side of the coach.
2. Unplug and remove the factory pressure transducer from the pump, this will not be reused.
3. Locate this plug  in the kit and install it where the where the pressure transducer was removed.
4. Inspect the factory installed hose at both ends. If you have a 90 on both ends, then move to step 6. If one end is straight, then continue to step 5.
5. Remove the factory hose from the pump fitting
6. Locate this fitting  in the kit and install it onto the remaining fitting left in the pump where the hose was removed from. Install the fitting with it pointing toward the front of the coach.
7. Unplug the coil from the factory controller.

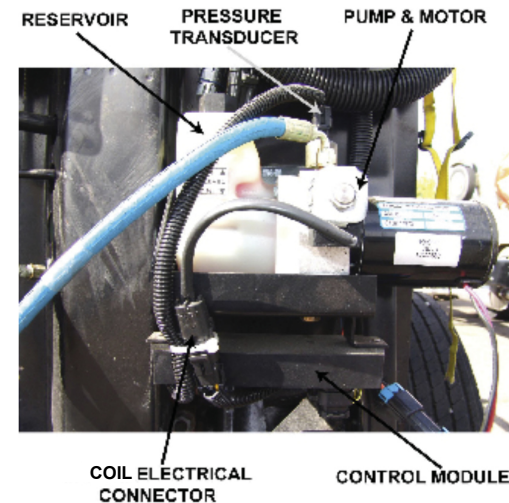



Installation Guide

J72 Parking Brake Control Kit

Application: Workhorse RV Chassis W24 & 05 P32

Model Years: 2004-2007

Part# US2078

Workhorse W24

For Workhorse W24 series the UltraSave and Controller will be mounted on the brake booster support bracket.

Take the UltraSave valve from the kit and orient it as shown below (Diagram 1a). Holding it up to the brake booster bracket as shown in diagram 1b mark the mounting hole locations making sure to not interfere with surrounding components, such as brake lines. Mount as close to the bottom as possible to leave room for the controller above it.

Using a 1/4" drill bit, drill through the brake booster bracket where you marked the mounting holes for the UltraSave.

Locate the 1/4" bolts supplied in the kit and install them with the washers on both sides of the UltraSave valve body, then install the bolts through the mounting holes then install the nut. Tighten the mounting bolts just enough to immobilize the valve, Over-tightening them can distort the valve body.

UltraSave Mounting Orientation

Workhorse W24

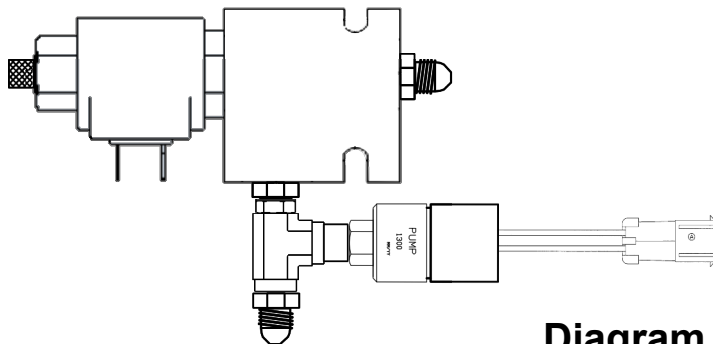
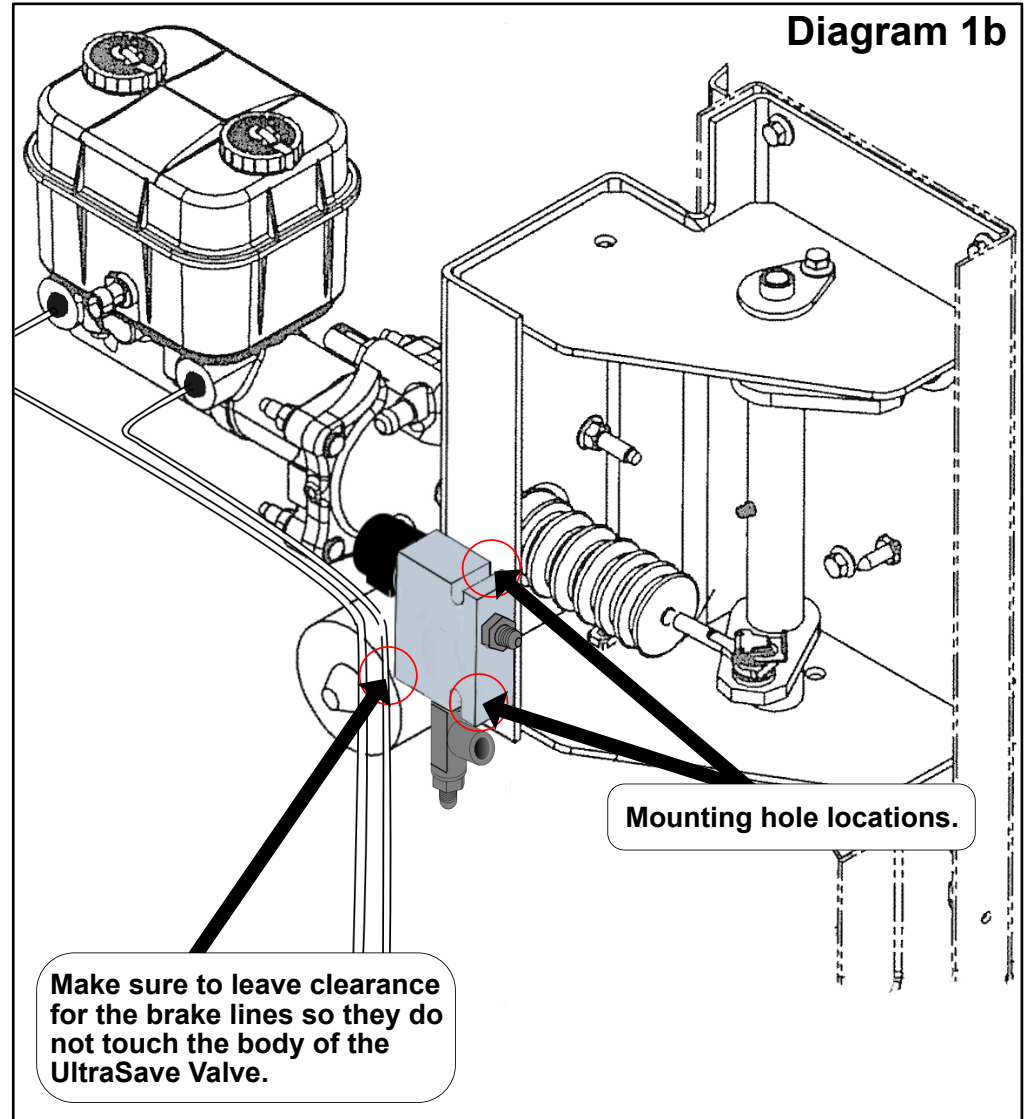

Diagram 1a

Diagram 1b



Mounting hole locations.

Make sure to leave clearance for the brake lines so they do not touch the body of the UltraSave Valve.



Installation Guide

J72 Parking Brake Control Kit

Application: Workhorse RV Chassis W24 & 05 P32

Model Years: 2004-2007

Part# US2078

Workhorse W24

For Workhorse W24 series the Controller will be mounted on the brake booster mounting support bracket.

Take the controller from the kit and orient it as shown (Diagram 2a). Holding it up to the brake booster bracket as shown in diagram 1b mark the mounting hole locations. Mount as close to the UltraSave valve as bottom as possible to leave room for the controller above it.

Using a 5/16" bit driver, drill the screws through the brake booster bracket where you marked the mounting holes for the Controller. Remove the screws when done, and install the controller using the mounting holes just drilled.

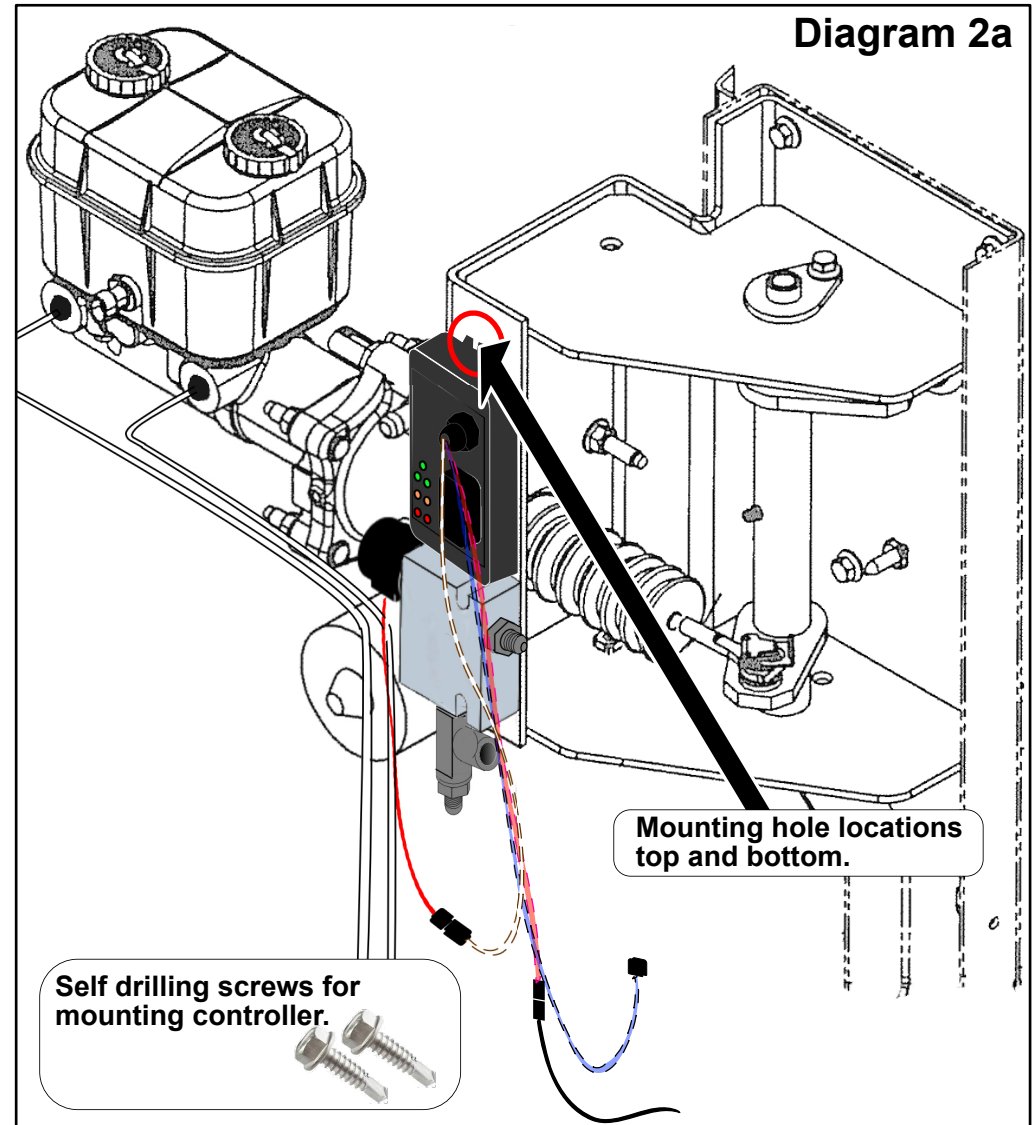

Diagram 2a

Mounting hole locations top and bottom.

Self drilling screws for mounting controller.



Installation Guide

J72 Parking Brake Control Kit

Application: Workhorse RV Chassis W24 & 05 P32

Model Years: 2004-2007

Part# US2078

Install Control Module & Connect Control Module

Wiring the controller is very simple. Unplug the 14 pin connector from the factory control module mounted under the pump, and install it into the 14 pin connector on the new module. Disregard the remaining two connectors that come from the factory control module, one that went to the factory transducer, and the other that went to the coil, they will no longer be used.

You will be left with three items to plug into the new control module listed here:

1. The new pressure switch will be installed as shown below (diagram 3a) and will be plugged into the cable from the control module with blue and black wires.
2. The pump coil will connect to the cable from the control module with red and black wires.
3. The line lock valve will connect to the cable from the control module with the white and brown wires.

The plugs from the module will only plug into the correct mate.

Diagram 3a

Install pressure switch into tee fitting.

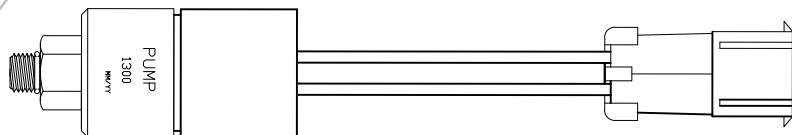

Do not over tighten, it seals on the o-ring not the threads.

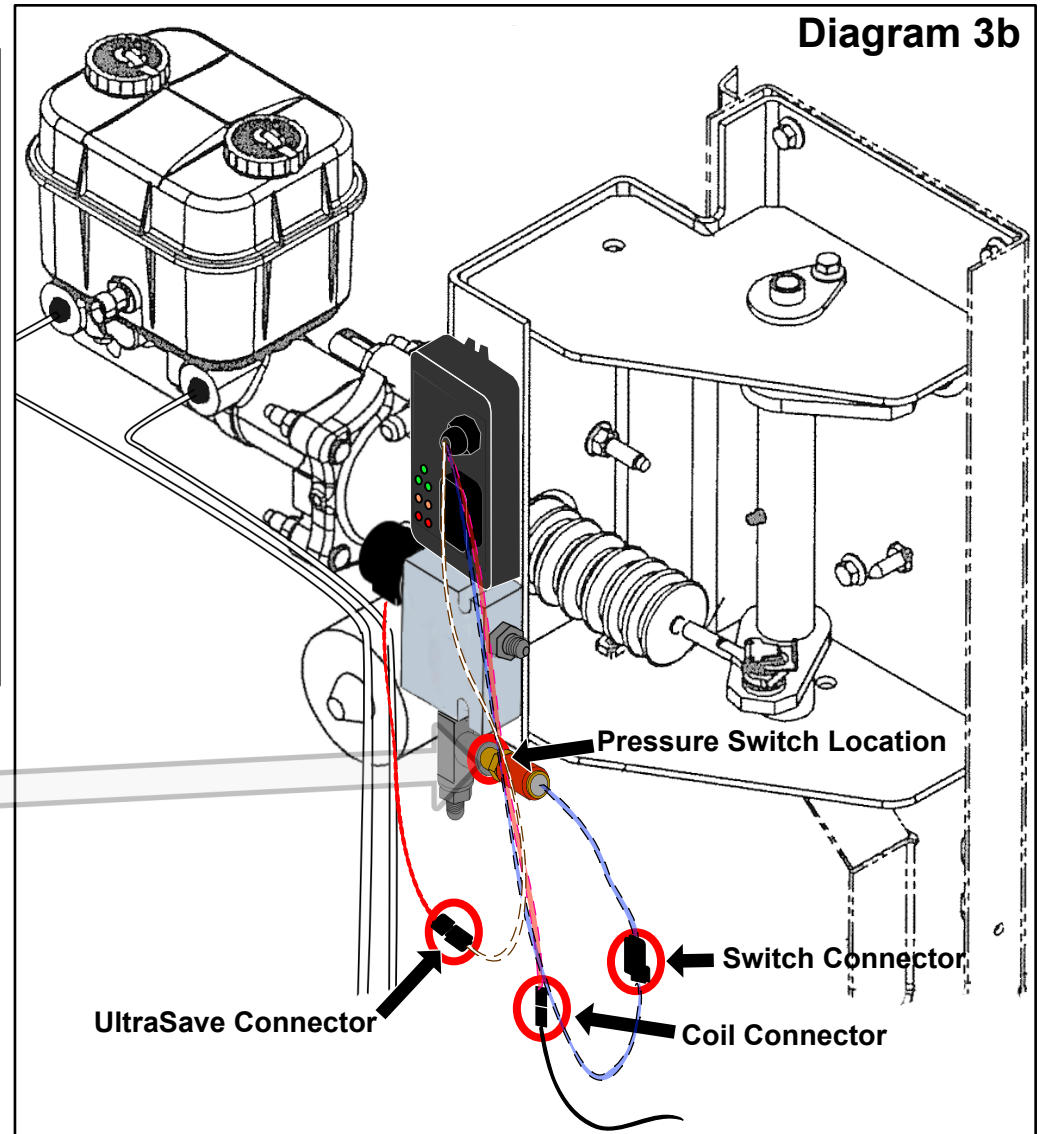



Installation Guide

J72 Parking Brake Control Kit

Application: Workhorse RV Chassis W24 & 05 P32

Model Years: 2004-2007

Part# US2078

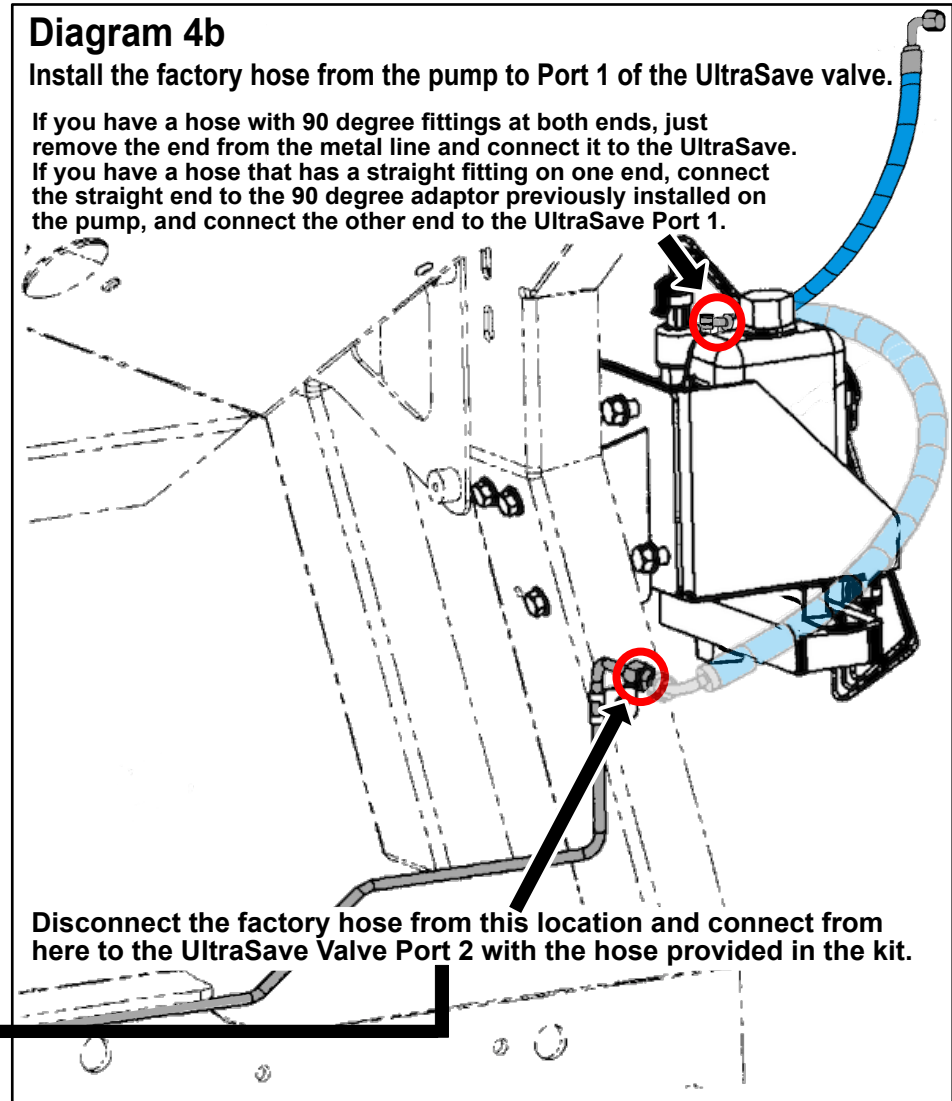
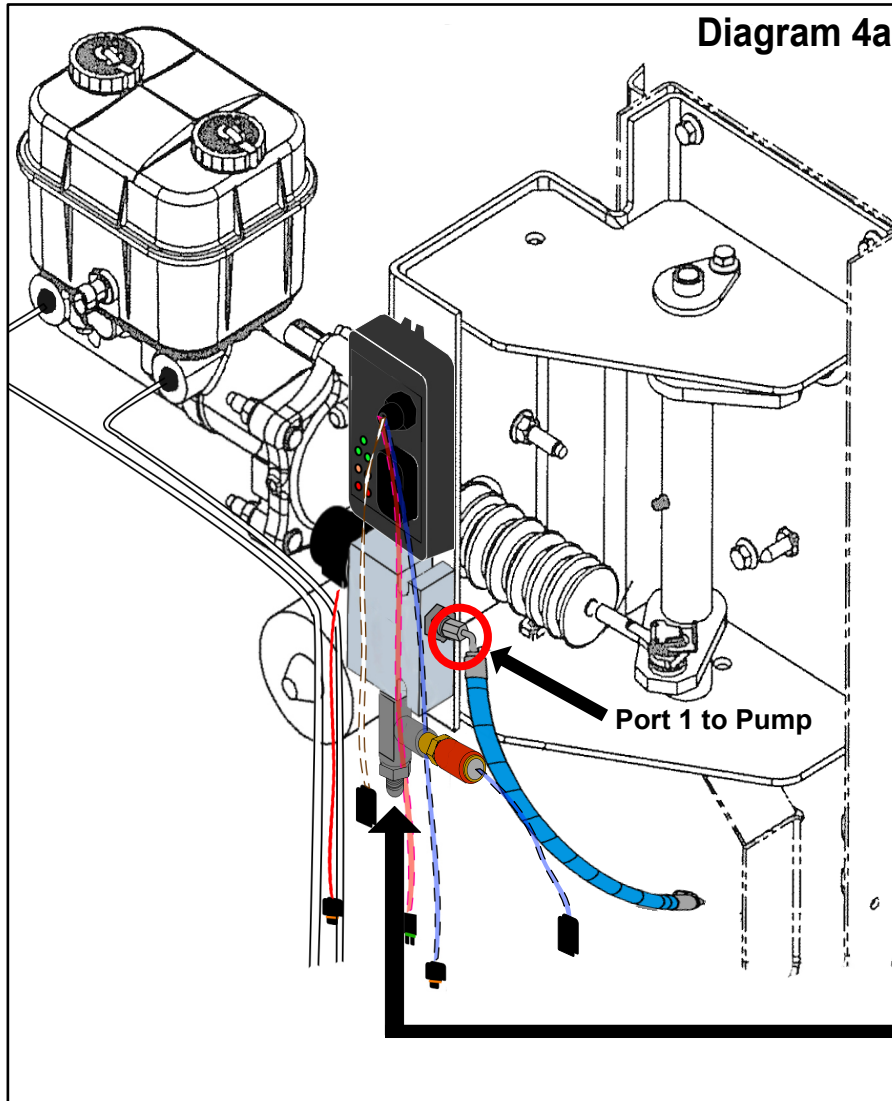



Installation Guide

J72 Parking Brake Control Kit

Application: Workhorse RV Chassis W24 & 05 P32

Model Years: 2004-2007

Part# US2078

Note:

During the time that you have your foot on the brake pedal and the engine is not running on a W24 you will hear the brake booster motor running, this is not the park brake pump, and it is normal for this to happen.

1. Sitting in the driver seat place your foot on the brake pedal.
2. Turn the ignition to the On position – Do not start the engine.
3. Push the yellow “Push-Pull” Button to the “In” position.
4. With your foot still on the brake pedal pull the shift lever into the drive position.
5. You should hear the park brake pump run for approximately 3-5 seconds.
6. Once the pump runs then you should see the “Auto Park” light on the cluster go out.
7. If these things happen as described, then place the coach back into park with your foot still on the brake pedal, and Workhorse the auto park light should come back on.
8. Now start the engine.
9. With the “Push-Pull” button still in, and your brake pedal pressed, place the coach in drive and slowly release the brake pedal.
10. The coach should move forward.
11. Press the brake pedal and stop the coach.
12. Pull out on the “Push-Pull” button and slowly release the brake pedal.
13. The coach should not move forward.
14. If all these things occurred as stated then the brake is working properly. If not please call 800-417-4559 to get technical assistance.

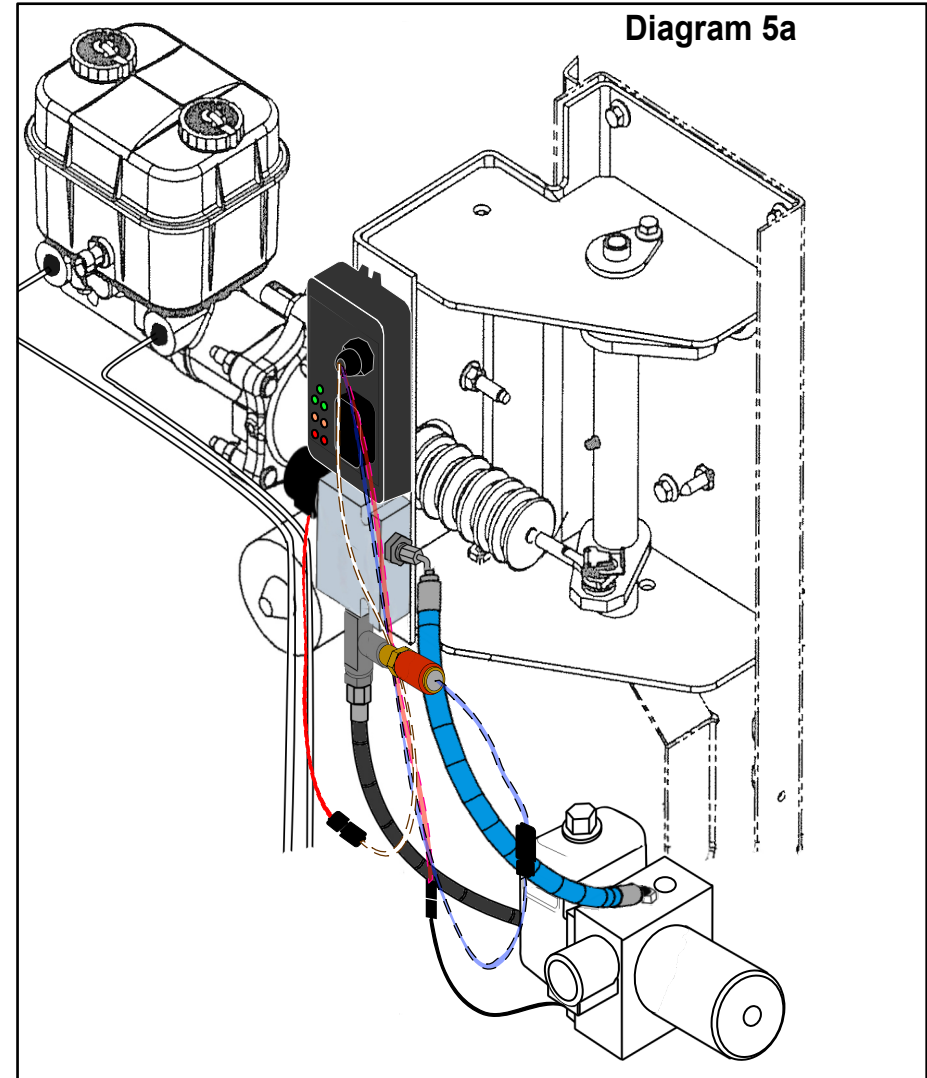



Important Information

Please Read And Inspect -
Very IMPORTANT!

W24 The location that is shown is on the inside of the driver side frame rail at the front of the coach just behind the radiator. You can see the steering gear bolt in the lower right of the photo. The power steering line rubs on the park brake metal line that goes back to the brake on the transmission. You **MUST** make sure this line is not contacting the power steering hose. If it is be sure that the metal line is not rubbed to badly. If there is a lot of damage then you must repair this line! If there is **very** minimal damage then you can just bend the power steering hose back away from it and cover the area that was contacting with rubber.

Manual Bypass Of The UltraSave

To manually bypass the UltraSave Valve you can push in and turn the Red Knob Counter Clockwise and the knob will pop up slightly. In this position the valve is bypassed and will allow flow of fluid through the valve at all times in both directions. To place the valve into normal operation just push in and turn the knob clockwise and the knob will stay in.

