

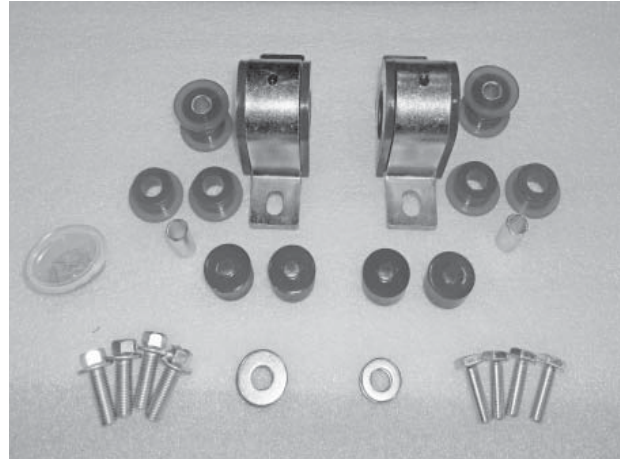

# Installation Instructions

## Polyurethane Bushing Kit for Ford F-53 (Rear) (replaces OE bushings and brackets)

part #4139-300  
1-3/8" diameter



## INTRODUCTION

Thank you for purchasing this polyurethane bushing kit. This kit is designed to improve the handling characteristics of your Ford F-53 by reducing the body roll and balancing the weight transfer during cornering. The bushing kit is engineered for long life and trouble-free performance. For maximum suspension control, use this kit along with our auxiliary anti-sway bar kit.

All the hardware needed for installation is included in this kit. Refer to the PARTS LIST in these instructions to identify the parts.

## SUGGESTED TOOLS

The following tools are suggested to complete the installation procedures:

- Metric wrenches
- Metric sockets
- Socket wrench
- Vise
- Cylinder smaller than 1-5/8" diameter (Step 4)
- Cylinder larger than 1-5/8" diameter (Step 4)

### **⚠ WARNING**

**Failure to follow these instructions can result in property damage, personal injury or even death.**

- If raising the vehicle to install the anti-sway bar, always support the vehicle with jack stands at both frame rails or at the rear axle before working underneath. Ensure that the jack stands are securely positioned, and are rated at or above the weight of the vehicle.
- The installer must read the instructions and use all bolts and parts supplied. Use only the parts supplied by ROADMASTER to install this kit.
- Minor modifications are sometimes necessary due to slight vehicle variations, even for the same year, make and model.
- Regardless of year, make and model, a wide range of options for specific applications may or may not interfere with the installation. It is the installer's responsibility to make certain that equipment is not damaged once the suspension solution travels through the full range of motion. Failure to ensure adequate clearance could result in non-warranty property damage, personal injury or even death.
- If running changes were made by the manufacturer after this kit was designed, there may be weldments, braces, gussets, or other structural items which interfere with the installation. It is the installer's responsibility to allow for these running changes without sacrificing the structural integrity of the anti-sway bar. Failure to securely fasten the anti-sway bar could result in property damage, personal injury or even death.
- ROADMASTER will not be responsible for any damage or injury resulting from any modification or alteration.
- Check ALL the fasteners for tightness before and after road testing the vehicle.
- Do not use this document for custom fabrication, as it may not show all parts or structural components.
- Do not use an air impact wrench when re-installing bolts, as stripped threads may result.
- This anti-sway bar is only warranted for the original installation. Installing a used anti-sway bar on another vehicle is not recommended and will void the warranty.

# PARTS LIST

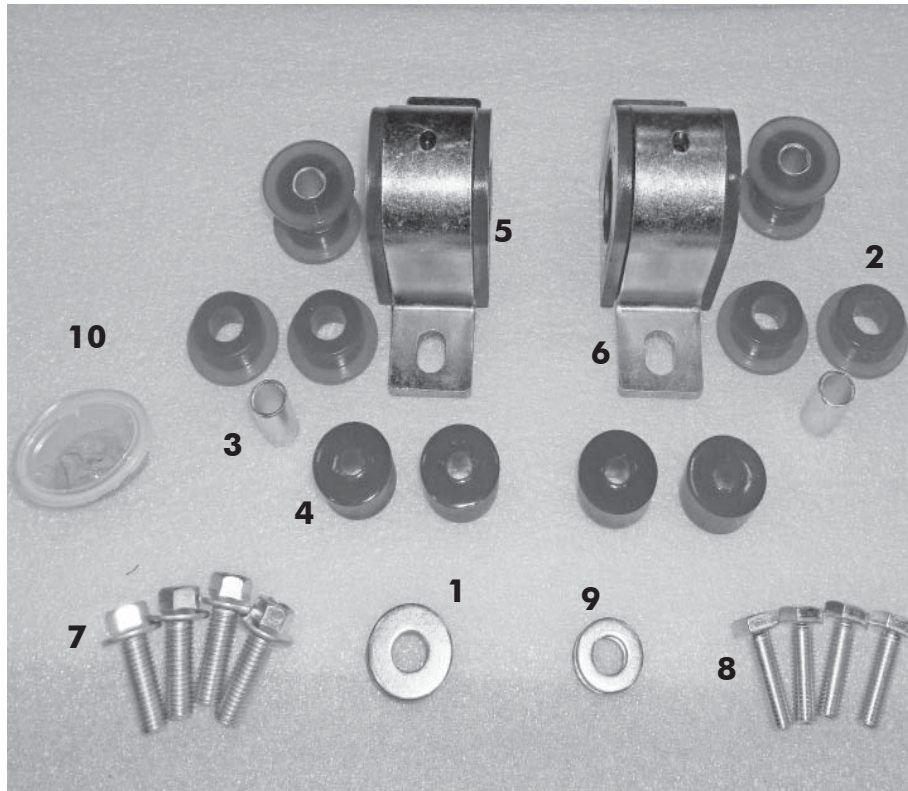

This drawing is for assembly information only

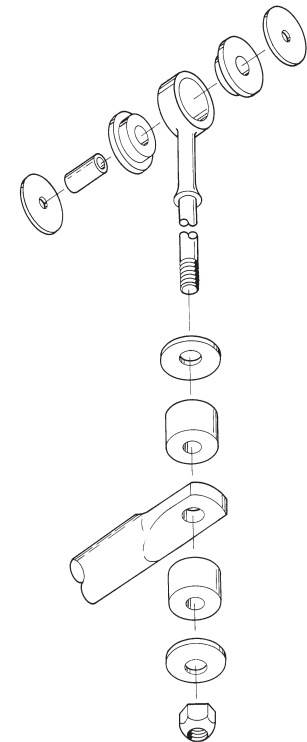

Part #4139-300

Part #	Description	Qty	Part #	Description	Qty
1. 350308-00	Washer, 1/2" large o.d	4	6. B141	Bracket, saddle	2
2. 205223-00	Bushing, poly hat	8	7. 357200-20	Bolt, 12mm	4
3. 205516-00	Sleeve, spacer	4	8. 356102-00	Bolt, 10mm	4
4. 205381-00	Poly bushing	4	9. 350308-20	Washer	4
5. 205219-10	Bushing, split	2	10. 400011-30	Aqualube Grease	1

## Free Extended Warranty

You must accurately and completely fill out and mail the product registration card within thirty (30) days from the date of purchase to qualify for your warranty. **If we receive your card, completely and accurately filled out, within twenty (20) days from the date of purchase, we will extend the coverage to a total of two (2) years at no extra charge.**

Your product registration is an important record for ROADMASTER to keep in touch with you. It also enables us to expedite any future claim, update or recall that may arise concerning our products.

# INSTALLATION

The following instructions must be followed in the order listed to ensure a proper installation and to preserve the ROADMASTER warranty.

**Support vehicle and remove the wheels**  
(Steps 1 and 2 are optional, for working room)

**1. Use a floor jack to raise the vehicle.**

Put the vehicle in Neutral. Put a floor jack under the frame and raise the vehicle so that the tires are off the ground.

**2. Put jack stands under the frame.**

Place the jack stands under the rear axle housing to correctly locate the mounting points for the links. Lower the axle housing onto the jack stands. Push the side of the body to make sure that the vehicle is stable.

## WARNING

If raising the vehicle to install the kit, always support the vehicle with jack stands at both frame rails or at the rear axle before working underneath. Ensure that the jack stands are securely positioned, and are rated at or above the weight of the vehicle.

**3. Remove the factory anti-sway bar bushings.**

**4. Remove the saddle brackets and bushings.**

Use the 13mm wrench and socket to remove the bolts from each saddle bracket. Remove the saddle bracket assemblies from the vehicle (Figure 1). Slide the bushings over or cut them off with a knife.

## CAUTION

Do not allow the anti-sway bar to hit the driveshaft, or it may damage the driveshaft. Damage to the driveshaft may result in unwanted vibration while driving the vehicle.

**5. Install the saddle bushings and brackets on the vehicle.**

Lubricate inside of the split bushing with the grease provided (Figure 2). Install bushing on sway bar and slide saddle bracket over bushings.

**6. Install bolts in the saddle brackets.**

Use either 10mm or 12mm bolts depending on which size bolts were removed. Washer (W421) may be needed to allow bolt to install fully (check to see if bolt touches axle tube).

**Figure 1**

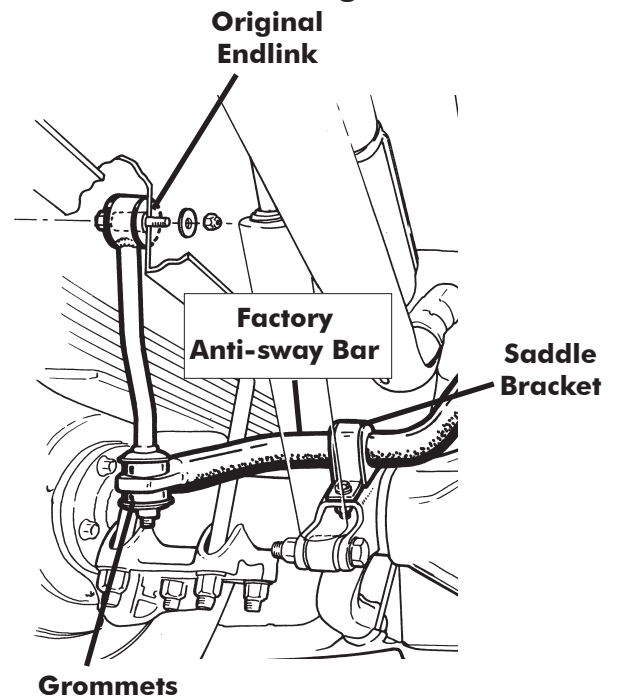

**Figure 2**

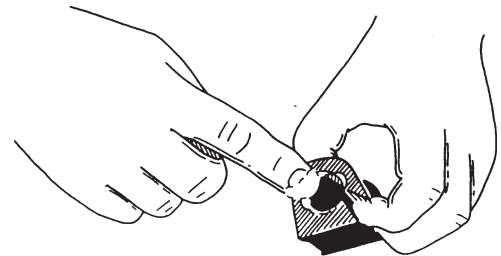

# INSTALLATION

## 7. Remove the bar from the endlinks.

Use the 15mm wrench to remove the nuts from the end of the links. Support the anti-sway bar end as you remove the nut from the second endlink.

### **WARNING**

Removing the endlinks will release the anti-sway bar. The anti-sway bar is heavy, and may cause property damage or personal injury if it falls on equipment, engine components or any part of your body. Ensure that the anti-sway bar is supported and that you are out of the way when removing the brackets.

Failure to follow these instructions may cause property damage, personal injury or even death.

## 8. Remove the endlinks.

Use a socket and wrench to remove the bolts and nut that hold each endlink to the vehicle frame. Note: due to manufacturing variances, some applications may need one horizontal and one vertical endlink piece or two vertical endlink pieces. If this is the case, not all pieces of this kit will be used.

## 9. Replace the bushings in the endlinks.

## 10. Remove the original bushings.

Find a socket or other cylinder that has a slightly larger ID than the endlink and another that has a slightly smaller OD than the bushing. Hold the link and sockets with a large vise so the small socket will push the bushing into the large socket. Tighten the vise to remove the bushing.

## 11. Install the bushings into the endlinks.

Insert one bushing into the endlink. Push the sleeve into the bushing until it reaches the side with the flange. Push the other bushing into the link (Figure 3).

## 12. Connect the endlinks to the anti-sway bar.

Install the original washer and a grommet on the endlink. Install the endlink assembly on the end of the anti-sway bar so that the grommet is on the top side of the anti-sway bar end.

Install another grommet and an original washer and start the nut. Install the grommets, washer and endlink for the other end of the anti-sway bar. Do not tighten the nuts at this time (Figure 4).

### **WARNING**

Over-tightening the grommets may cause premature failure of the grommets and/or the endlinks. If the grommets fail, the bushing kit will not stabilize the vehicle at full capacity, which may cause reduced cornering ability or other reductions in vehicle handling or performance. Failure to follow these instructions may result in property damage, personal injury or even death.

**Figure 3**

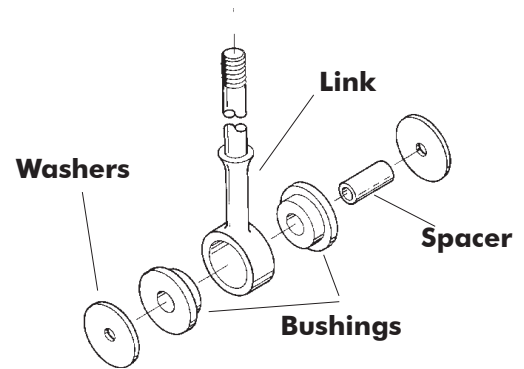

**Figure 4**

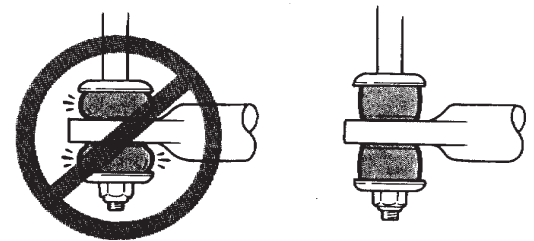

**13. Re-attach the endlinks to the frame.**

**14. Check the anti-sway bar and tighten fasteners.**

Make sure the anti-sway bar is centered, side-to-side. Tighten fasteners but do not over-tighten grommets.

**15. Replace the wheels and road test THE VEHICLE.**

 **WARNING**

After road testing, re-check all fasteners for proper tightness — if a fastener has worked loose or fallen off, re-tighten or replace it. Without all kit components properly tightened or in place, the bushing kit will not stabilize the vehicle at full capacity, which may cause reduced cornering ability or other reductions in vehicle handling or performance.

Failure to follow these instructions may result in property damage, personal injury or even death.

# LIMITED WARRANTY

## 1. WARRANTY

### 1a. WARRANTY OF CONFORMITY AT TIME OF SALE

ROADMASTER, Inc. warrants that at the time of sale of this product it will be free from defects in material and manufacture and will conform to ROADMASTER'S specifications for the product.

### 1b. CONDITIONAL ONE-YEAR WARRANTY

In addition to the preceding time-of-sale warranty, if the product registration card is completely and accurately filled out and mailed to ROADMASTER within thirty (30) days of purchase, ROADMASTER will provide an additional warranty that for a period of one year after sale the product will remain in good working order, PROVIDED THAT the product is installed and maintained in accordance with ROADMASTER'S instructions and is not subjected to: (a) alteration or unauthorized repairs or repairs by anyone other than ROADMASTER or a ROADMASTER-authorized service center, (b) misuse, abuse, commercial use, or improper maintenance, (c) Acts of God (including without limitation hurricanes, tornadoes, floods, or other severe weather or natural phenomena), (d) failures due to products not supplied by ROADMASTER, or (e) other treatments, uses, or installations for which the product was not intended. This warranty extends only to the first retail purchaser-consumer of the product and is not transferable.

**EXTENDED WARRANTY PERIOD:** If ROADMASTER receives the product registration card, completely and accurately filled out, within twenty (20) days of purchase, ROADMASTER will enlarge the one-year warranty period in the preceding paragraph to a period of two years.

## 2. DISCLAIMER OF OTHER WARRANTIES

The preceding warranties are the exclusive and sole express warranties given by ROADMASTER. They supersede any prior, contrary or additional representations, whether oral or written. No agent, representative, dealer or employee has the authority to alter or increase the obligations or limitations of this warranty. Any implied warranties, including the WARRANTY OF MERCHANTABILITY and any WARRANTY OF FITNESS FOR A PARTICULAR PURPOSE, are limited in duration to thirty days or the term of the applicable express warranty provided above, whichever is longer.

Some states do not allow limitations on how long an implied warranty lasts, so the above limitation may not apply to you.

## 3. EXCLUSIVE REMEDY FOR ANY NONCONFORMITIES

If during the applicable Warranty Period, the product does not conform to the preceding Warranties, notify ROADMASTER as provided below, and within a reasonable time ROADMASTER will provide, at its option, one of the following: (1) replacement components for any nonconforming or defective product or components or (2) the percentage of the purchase price for the nonconforming product equal to the percentage of the Warranty Period remaining when ROADMASTER is notified of the nonconformity. ROADMASTER will, at its option, (a) use new and/or reconditioned parts in performing warranty repairs and making replacement products, (b) use parts or products of original or improved design in the repair or replacement. If ROADMASTER repairs or replaces a product, its warranty continues for the remaining portion of the original Warranty Period or 60 days from the date of the return shipment to the customer, whichever is greater. All replaced products and all parts removed from repaired products become the property of ROADMASTER. ROADMASTER will not provide, and will not be liable for, labor, costs of removal or reinstallation of components, disposal, shipping, freight, taxes, or other incidental charges.

### THESE REMEDIES ARE THE EXCLUSIVE AND SOLE REMEDIES FOR ANY BREACH OF WARRANTY.

For any breach of warranty, the Owner must telephone ROADMASTER at 1-800-669-9690 within thirty (30) days after discovering the nonconformity. Do not return any product without first calling ROADMASTER and getting a return authorization number. Returned products must include the return authorization number and a copy of the original invoice, bill or other proof of the date of purchase. The date of purchase must coincide with the original warranty registration card on file. ROADMASTER will authorize (a) shipment of the product to ROADMASTER or (b) repair or replacement at the nearest warranty service center—in both cases with shipping at your expense. Do not purchase replacement parts or pay for repair labor—you will not be reimbursed. Compliance with the requirements of this paragraph is a condition to coverage under the Warranty: if these requirements are not complied with, ROADMASTER will have no obligation to provide any remedy for any breach of warranty.

## 4. DISCLAIMER OF INCIDENTAL AND CONSEQUENTIAL DAMAGES

IN NO EVENT SHALL ROADMASTER BE LIABLE FOR ANY INCIDENTAL, SPECIAL, INDIRECT OR CONSEQUENTIAL DAMAGES, WHETHER RESULTING FROM NONDELIVERY OR FROM THE USE, MISUSE OR INABILITY TO USE THE PRODUCT OR FROM DEFECTS IN THE PRODUCT.

Some states do not allow the exclusion or limitation of incidental or consequential damages, so the above limitation may not apply to you.

## 5. APPLICABLE LAW

This Warranty will be interpreted, construed, and enforced in all respects in accordance with the laws of the State of Washington, without reference to its choice of law rules. The U.N. Convention on Contracts for the International Sale of Goods will not apply to this Warranty.

## 6. SEVERABILITY

If any provision of this warranty is found to be invalid or unenforceable, then the remainder shall have full force and effect, and the invalid provision shall be partially enforced to the maximum extent permitted by law to effectuate the purpose of the agreement.

## 7. ADDRESS FOR NOTICES TO ROADMASTER

ROADMASTER, Inc., 6110 NE 127th Ave., Vancouver, WA 98682

This warranty gives you specific legal rights, and you may also have other rights which vary from State to State.