



# Installation Guide

## *J72 Replacement Parking Brake Pump*

**Application: Workhorse RV Chassis W24 & 2005 P32**

**Model Years: 2004-2008**

**Part# WH005667**

---

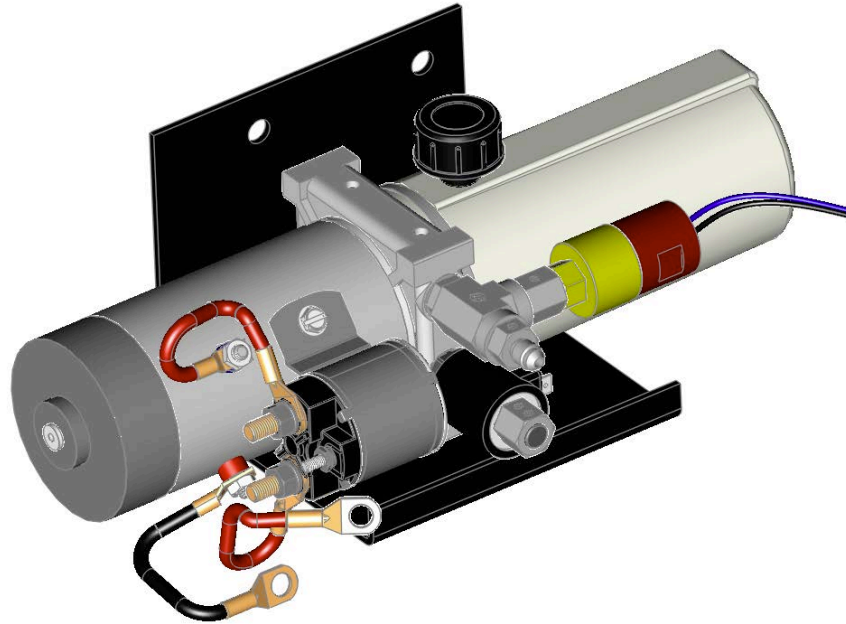

This is a direct replacement pump assembly for the W8005667 Workhorse parking brake pump, with the exception of two additional power and ground cables that need to be connected.

This pump is also suitable for use in replacing the J71 style pumps used in model years 2001-2004 Workhorse Chassis. When ordered for this application it will be shipped with the J71 connectors so it will be plug and play.

These cables are used so the pump does not draw the motor load through the factory relay. We now use that relay to power the solenoid mounted to the new pump motor. Drawing the load through the solenoid instead, greatly increasing the life of the factory pump motor relay.



# Installation Guide

## *J72 Replacement Parking Brake Pump*

Application: Workhorse RV Chassis W24 & 2005 P32

Model Years: 2004-2008

Part# WH005667

1. Please connect these new cables as follows:
  - a. Cable with **BLACK** heat shrink: This will be connected to any good chassis ground the cable can easily reach.
  - b. Cable with **RED** heat shrink: Connect to one of the open power studs at the bottom of the under-hood fuse block. (Shown in the diagram below.) Ensure there is a 30 or 40 amp min fuse installed in the corresponding fuse locations the cable is connected to.

